

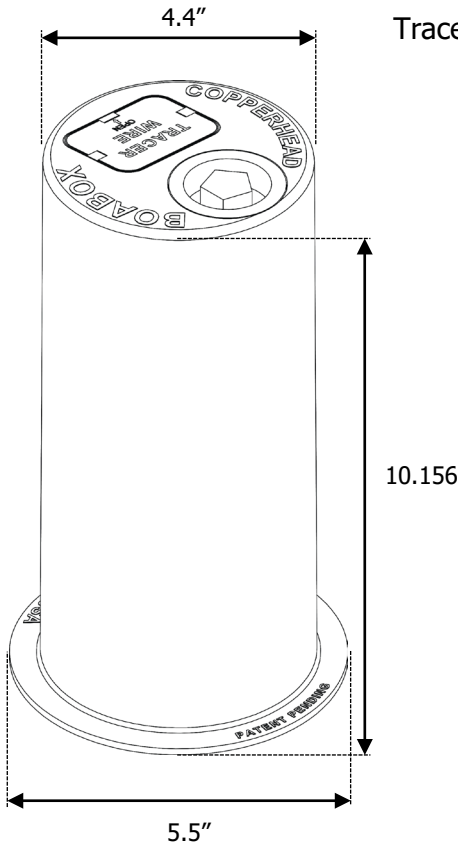

BOABOX™ WATER ACCESS POINT

APPLICATION

Integrated curb and tracer box for the water market. Provides efficient access to curb box and tracer wire system in one unit. The dual compartment and integrated entry points **eliminate the need for two lids in a yard or right-of-way**. Slips over new or existing curb box stand pipe. Can connect and disconnect tracer wire ground from top of unit. One unit rather than two saves time and money in installation.



Product Weight: 1.5 lbs.

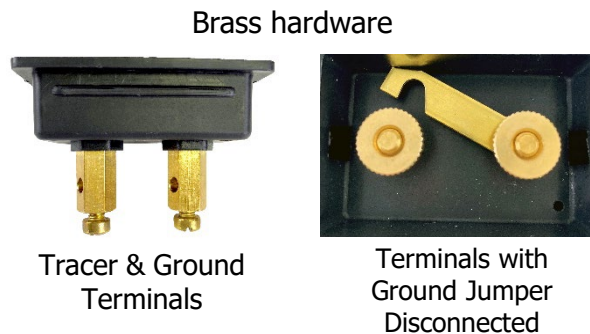
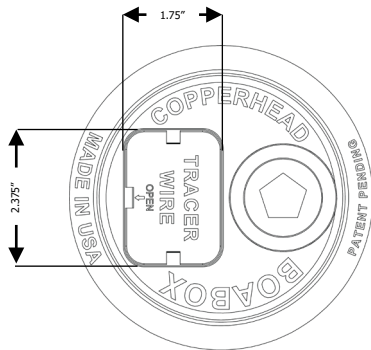

Tracer & Ground Terminals

Terminals with Ground Jumper Disconnected

BOABOX 125 – for 1" and 1 ¼" iron pipe size (IPS) standpipes
BOABOX 150 – for 1 ½" iron pipe size (IPS) standpipes

Patent No. 11,814,824



Profile

Bottom

FEATURES AND BENEFITS

- Two access points in one – curb box and tracer wire system
- Direct connection to tracer wire and ground rod from the top
- Two sizes fit 1", 1 ¼", and 1 ½" IPS standpipes
- Bottom flange adds strength and anchors into ground to accommodate earth's movement
- Encapsulated magnet in curb stop plug allows for detection by a ferrous metal detector
- ¼-turn pentagon style plug – NO cross threading
- Brass hardware means no rusting or seizing parts
- UV resistant, composite material
- Anti-corrosion gel protects wires
- Made in the USA



SPECIFICATIONS

SCOPE

These specifications apply to the BoaBox™ Water access point, designed for operational access to underground curb box and tracer wire system. Suitable for installation with new or existing curb box risers.

MATERIAL AND DESIGN

Material

- Curb and tracer box body, flange, and covers shall be injection molded, UV resistant composite.
- Curb and tracer box shall be compression tested to 3,000 pounds and show no signs of damage.
- Tracer wire terminals, thumb nuts, and jumper shall be brass for flawless continuity.
- Manufacturer shall supply dielectric, anti-corrosive gel to protect wires.
- Top shall be designed with magnet securely attached to be easily detected by magnetic locators even when access point is covered by soil, sod, and/or paving material.
- Curb and tracer box shall be 100% made in the USA.
- Curb and tracer box shall have a one-year warranty against material and manufacturing defects.

Design

- Curb and tracer box shall be tubular (cylindrical) in shape.
- Curb and tracer box shall have two separate entry points in one integral housing. One entry point shall allow for connection of tracer and ground wires. The other entry point shall allow for installation over a 1", 1 ¼", or 1 ½" water service curb box riser.
- Curb and tracer box shall have two separate access covers in one integral housing. To eliminate cross-threading, neither cover shall thread into the curb and tracer box.
 - One access point shall have a snap-on rectangular cover to provide at-grade access to tracer wire. Cover shall be labeled "TRACER WIRE". Beneath the tracer wire cover shall be (2) terminal points, (2) thumb nuts and a jumper to ensure correct tracer and ground wire installation.
 - One access point shall have a ¼-turn round cover with pentagon plug to provide above-ground access to the curb stop. Cover shall be labeled "WATER".
- Tracer wire compartment shall be sized to allow for 12-24 inches of excess tracer wire.
- Curb and tracer box shall have an integral flange base which adds overall strength in both directions. It shall allow curb and tracer box to be anchored into the soil while also allowing for simultaneous soil and box movement.
- Top of curb box standpipe should be located 4" – 5" below finish grade and/or half-way on the BoaBox Water (curb box standpipe chamber).

Position

- Access point designed so that when installed, the top will be flush with the ground.

QUALITY ASSURANCE

- Copperhead products are manufactured under a quality control system that ensures products are free of defects and meet performance requirements.
- Copperhead provides best-in-class customer service. We promise to put forth our best efforts for our customers and to treat everyone we encounter with courtesy and respect.

